

# NT3H1101/NT3H1201

NTAG I<sup>2</sup>C, NFC Forum type 2 Tag compliant IC with I<sup>2</sup>C interface

Rev. 1 — 19 December 2013  
257710

Objective short data sheet  
COMPANY PUBLIC

## 1. General description

The NTAG I<sup>2</sup>C is the first product of NXP's NTAG family offering both contactless and contact interfaces (see [Figure 1](#)). In addition to the passive NFC Forum compliant contactless interface, the IC features an I<sup>2</sup>C contact interface, which can communicate with a microcontroller if the NTAG I<sup>2</sup>C is powered from an external power supply. An additional externally powered SRAM mapped into the memory allows a fast data transfer between the RF and I<sup>2</sup>C interfaces and vice versa, without the write cycle limitations of the EEPROM memory.

The NTAG I<sup>2</sup>C product features a configurable Field Detection Pin, which provides a trigger to an external device depending on the activities at the RF interface.

The NTAG I<sup>2</sup>C product can also supply power to external (low power) devices (e.g., a microcontroller) via the embedded energy harvesting circuitry.

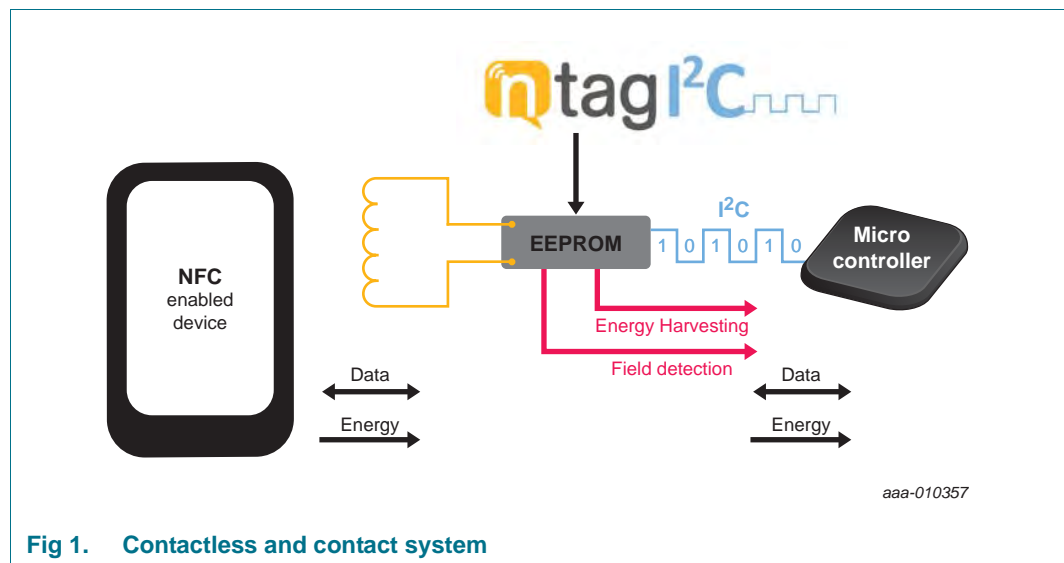

Fig 1. Contactless and contact system

## 2. Features and benefits

### 2.1 Key features

- RF interface NFC forum Type 2 Tag compliant
- I<sup>2</sup>C interface
- Configurable field detection pin based on open drain implementation that can be triggered upon the following events:
  - ◆ A RF field presence
  - ◆ The first Start-of-Frame
  - ◆ The selection of the tag only
- 64 byte SRAM buffer for fast transfer of data (Pass-through mode) between the RF and the I<sup>2</sup>C interfaces located outside the User Memory
- Wake up signal at the field detect pin when:
  - ◆ New data has arrived from one interface
  - ◆ Data has been read by the receiving interface
- Clear arbitration between RF and I<sup>2</sup>C interfaces:
  - ◆ First come, first serve strategy
  - ◆ Status flag bits to signal if one interface is busy writing to or reading data from the EEPROM
- Energy harvesting functionality to power external devices (e.g. microcontroller)
- FAST READ command for faster data reading

### 2.2 RF interface

- Contactless transmission of data
- NFC Forum Type 2 tag compliant (see [Ref. 1](#))
- Operating frequency of 13.56 MHz
- Data transfer of 106 kbit/s
- 4 bytes (one page) written including all overhead in 4,8 ms via EEPROM or 0,8 ms via SRAM (Pass-through mode)
- Data integrity of 16-bit CRC, parity, bit coding, bit counting
- Operating distance of up to 100 mm (depending on various parameters, such as field strength and antenna geometry)
- True anticollision
- Unique 7 byte serial number (cascade level 2 according to ISO/IEC 14443-3 (see [Ref. 2](#)))

### 2.3 Memory

- 1904 bytes freely available with User Read/Write area (476 pages with 4 bytes per pages) for the NTAG I<sup>2</sup>C 2k version
- 888 bytes freely available with User Read/Write area (222 pages with 4 bytes per pages) for the NTAG I<sup>2</sup>C 1k version
- Field programmable read-only locking function with static and dynamic lock bits
- Write protection configurable from both I<sup>2</sup>C and NFC interfaces
- 64 bytes SRAM volatile memory without write endurance limitation

- Data retention time of 20 years
- Write endurance 200,000 cycles

## 2.4 I<sup>2</sup>C interface

- I<sup>2</sup>C slave interface supports Standard (100 kHz) and Fast (up to 400 kHz) mode (see [Ref. 3](#))
- 16 bytes (one block) written in 4,5ms (EEPROM) or 0,4ms (SRAM - Pass-through mode) including all overhead
- RFID chip can be used as standard I<sup>2</sup>C EEPROM

## 2.5 Security

- Manufacturer-programmed 7-byte UID for each device
- Capability container with one time programmable bits
- Field programmable read-only locking function per page (per 32 pages for the extended memory section)

## 2.6 Key benefits

- The Pass-through mode allows fast download and upload of data from RF to I<sup>2</sup>C and vice versa without the cycling limitation of EEPROM
- NDEF message storage up to 1904 bytes (2k version) or up to 888 bytes (1k version)
- The mapping of the SRAM inside the User Memory buffer allows dynamic update of NDEF message content

## 3. Applications

---

With all its integrated features and functions the NTAG I<sup>2</sup>C is the ideal solution to enable a contactless communication via an NFC device (e.g., NFC enabled mobile phone) to an electronic device for:

- Zero power configuration (late customization)
- Smart customer interaction (e.g., easier after sales service, such as firmware update)
- Advanced pairing (for e.g., WiFi or Blue tooth) for dynamic generation of sessions keys

Easier product customization and customer experience for the following applications:

- Home automation
- Home appliances
- Consumer electronics
- Healthcare
- Printers
- Smart meters

## 4. Quick reference data

**Table 1. Quick reference data**

In accordance with the Absolute Maximum Rating System (IEC 60134).<sup>[1][2][3]</sup>

Symbol	Parameter	Conditions	Min	Typ	Max	Unit
C <sub>i</sub>	input capacitance	LA - LB <sup>[4]</sup>	44	50	56	pF
f <sub>i</sub>	input frequency		-	13.56	-	MHz
<b>Energy harvesting characteristics</b>						
V <sub>out</sub>	Voltage generated at the V <sub>out</sub> pin		-	-	3.2	V
<b>I<sup>2</sup>C interface characteristics</b>						
VCC	Supply voltage	I <sup>2</sup> C on VCC input	1.8	-	3.6	V <sub>m</sub>
I <sub>DD</sub>	Supply current		-	155	-	μA
<b>EEPROM characteristics</b>						
t <sub>ret</sub>	retention time	T <sub>amb</sub> = 22 °C	20	-	-	year
N <sub>endu(W)</sub>	write endurance	T <sub>amb</sub> = 22 °C	200000	-	-	cycle

[1] Stresses above one or more of the limiting values may cause permanent damage to the device.

[2] These are stress ratings only. Operation of the device at these or any other conditions above those given in the Characteristics section of the specification is not implied.

[3] Exposure to limiting values for extended periods may affect device reliability.

[4] LCR meter, T<sub>amb</sub> = 22 °C, f<sub>i</sub> = 13.56 MHz, 2 V RMS

**Remark:** The values above are target values; final values will be available after product characterization and may deviate from these preliminary values.

## 5. Ordering information

**Table 2. Ordering information**

Type number	Package		Version
	Name	Description	
NT3H1101W0FHK	XQFN8	Plastic, extremely thin quad flat package; no leads; 8 terminals; body 1.6 x 1.6 x 0.6mm; 1k bytes memory, 50pF input capacitance	SOT902-3
NT3H1201W0FHK	XQFN8	Plastic, extremely thin quad flat package; no leads; 8 terminals; body 1.6 x 1.6 x 0.6mm; 2k bytes memory, 50pF input capacitance	SOT902-3

## 6. Block diagram

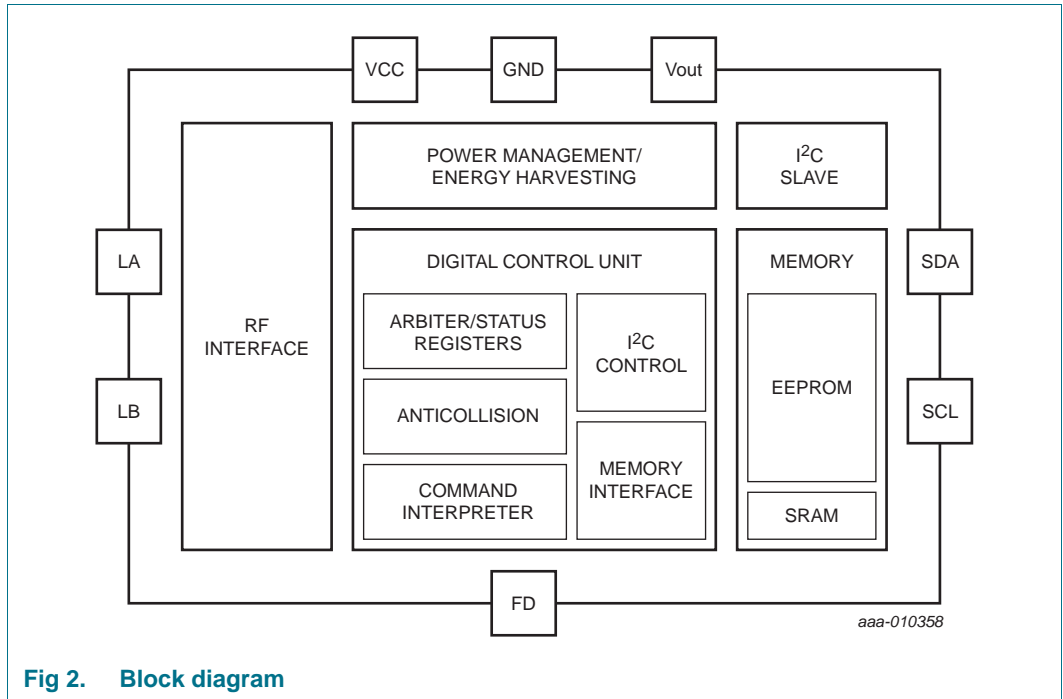

**Fig 2. Block diagram**

## 7. Pinning information

### 7.1 Pinning

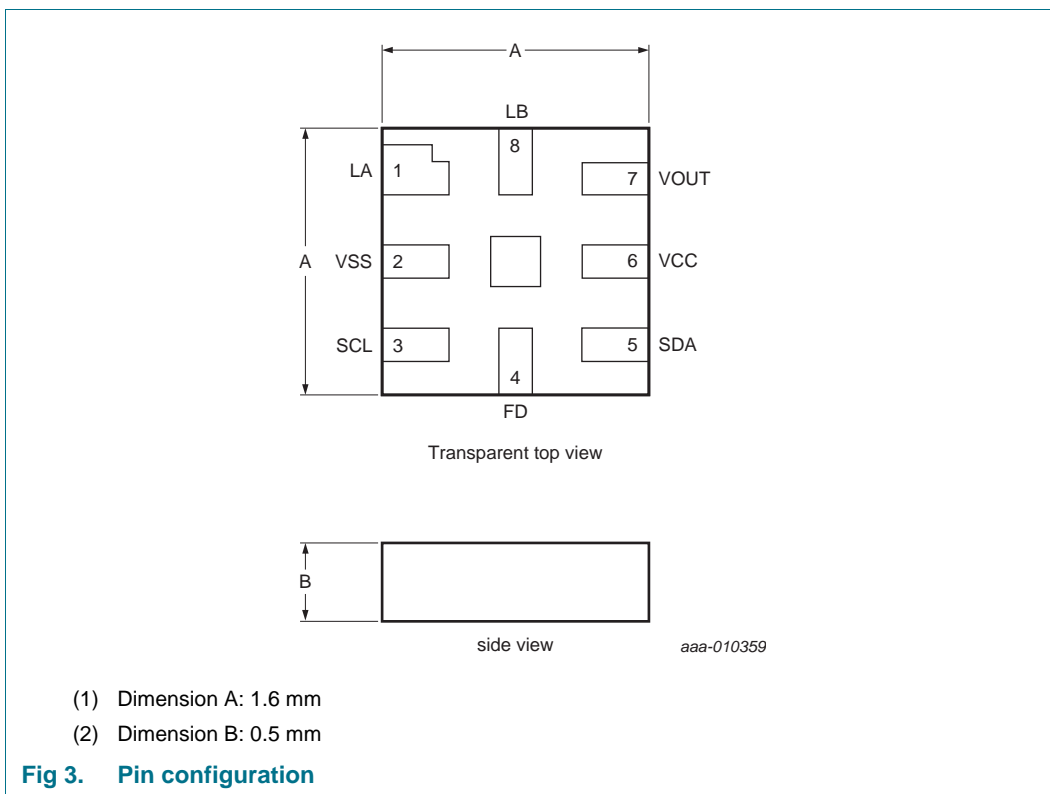

### 7.2 Pin description

**Table 3. Pin description**

Symbol	Pin	Description
Pin	Symbol	Description
1	LA	Antenna connection LA
2	VSS	GND
3	SCL	Serial Clock I <sup>2</sup> C
4	FD	Field detection
5	SDA	Serial data I <sup>2</sup> C
6	VCC	VCC in connection (external power supply)
7	V <sub>out</sub>	Voltage out (energy harvesting)
8	LB	Antenna connection LB

NXP recommends leaving the central pad of the package unconnected.

## 8. Limiting values

Exceeding the limits of one or more values in reference may cause permanent damage to the device. Exposure to limiting values for extended periods may affect device reliability.

**Table 4. Limiting values**

*In accordance with the Absolute Maximum Rating System (IEC 60134).*

Symbol	Parameter	Conditions	Min	Max	Unit
T <sub>stg</sub>	storage temperature		-55	+125	°C
T <sub>amb</sub>	ambient temperature		-40	+85	°C
V <sub>ESD</sub>	electrostatic discharge voltage		2	-	kV
V <sub>FD</sub>	Voltage on the FD pin		-	3.6	V
V <sub>SDA</sub>	Voltage on the SDA line		-	3.6	V
V <sub>SCL</sub>	Voltage on the SCL line		-	3.6	V

[1] ANSI/ESDA/JEDEC JS-001; Human body model: C = 100 pF, R = 1.5 kΩ.

**Remark:** The values above are target values; final values will be available after product characterization and may deviate from these preliminary values.

9. Package outline

XQFN8: plastic, extremely thin quad flat package; no leads;  
8 terminals; body 1.6 x 1.6 x 0.5 mm

SOT902-3

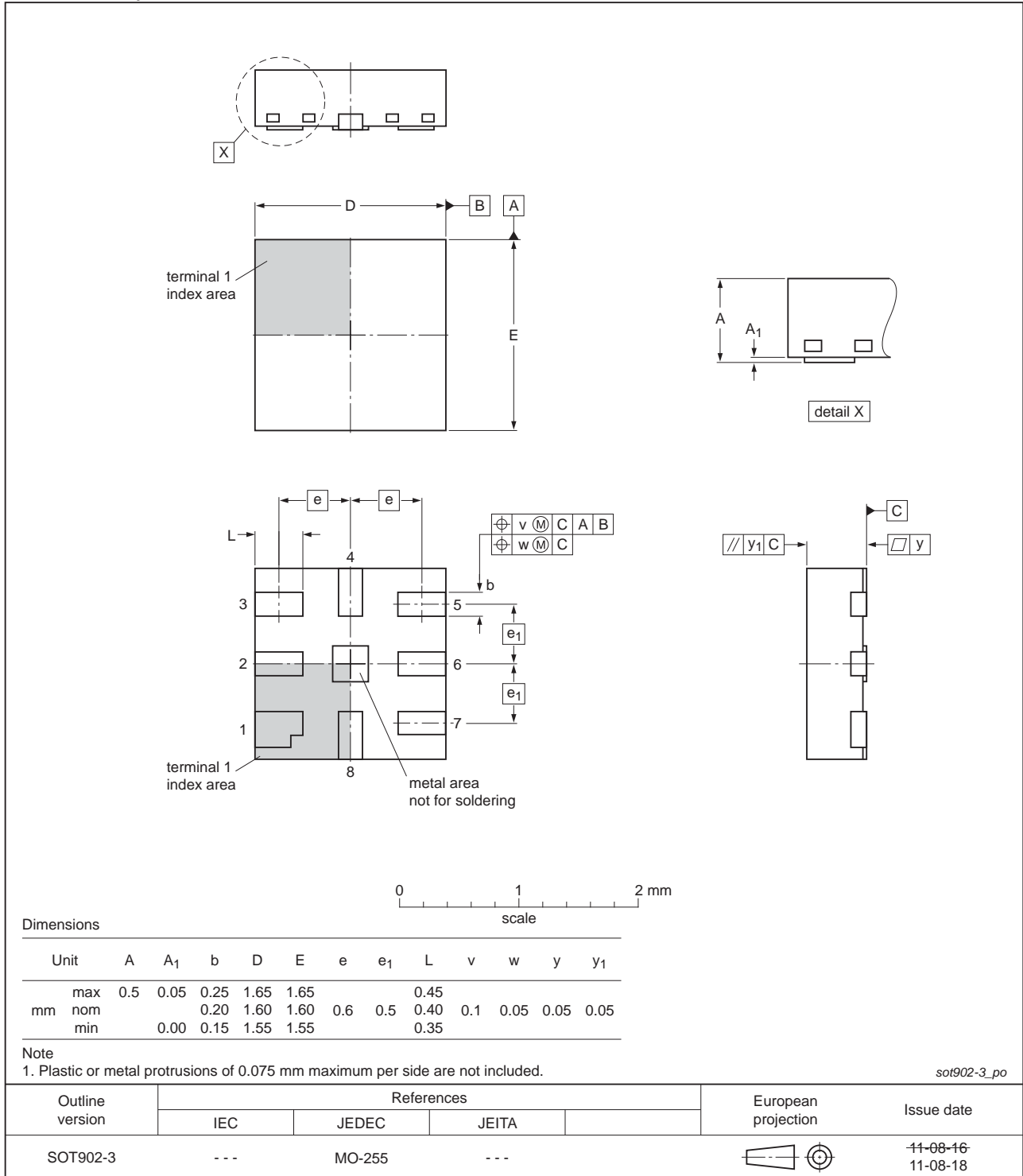

Fig 4. Package outline SOT902-3 (XQFN8)

## 10. References

---

- [1] NFC Forum Tag 2 Type Operation, Technical Specification - NFC Forum, 31.05.2011, Version 1.1
- [2] ISO/IEC 14443 - International Organization for Standardization
- [3] I2C-bus specification and user manual (NXP standard UM10204.pdf / Rev. 03 - 19 June 2007)

## 11. Revision history

Table 5. Revision history

Document ID	Release date	Data sheet status	Change notice	Supersedes
NT3H1101_1201_SDS v.1	20131219	Objective short data sheet	-	-

## 12. Legal information

### 12.1 Data sheet status

Document status <sup>[1][2]</sup>	Product status <sup>[3]</sup>	Definition
Objective [short] data sheet	Development	This document contains data from the objective specification for product development.
Preliminary [short] data sheet	Qualification	This document contains data from the preliminary specification.
Product [short] data sheet	Production	This document contains the product specification.

[1] Please consult the most recently issued document before initiating or completing a design.

[2] The term 'short data sheet' is explained in section "Definitions".

[3] The product status of device(s) described in this document may have changed since this document was published and may differ in case of multiple devices. The latest product status information is available on the Internet at URL <http://www.nxp.com>.

### 12.2 Definitions

**Draft** — The document is a draft version only. The content is still under internal review and subject to formal approval, which may result in modifications or additions. NXP Semiconductors does not give any representations or warranties as to the accuracy or completeness of information included herein and shall have no liability for the consequences of use of such information.

**Short data sheet** — A short data sheet is an extract from a full data sheet with the same product type number(s) and title. A short data sheet is intended for quick reference only and should not be relied upon to contain detailed and full information. For detailed and full information see the relevant full data sheet, which is available on request via the local NXP Semiconductors sales office. In case of any inconsistency or conflict with the short data sheet, the full data sheet shall prevail.

**Product specification** — The information and data provided in a Product data sheet shall define the specification of the product as agreed between NXP Semiconductors and its customer, unless NXP Semiconductors and customer have explicitly agreed otherwise in writing. In no event however, shall an agreement be valid in which the NXP Semiconductors product is deemed to offer functions and qualities beyond those described in the Product data sheet.

### 12.3 Disclaimers

**Limited warranty and liability** — Information in this document is believed to be accurate and reliable. However, NXP Semiconductors does not give any representations or warranties, expressed or implied, as to the accuracy or completeness of such information and shall have no liability for the consequences of use of such information. NXP Semiconductors takes no responsibility for the content in this document if provided by an information source outside of NXP Semiconductors.

In no event shall NXP Semiconductors be liable for any indirect, incidental, punitive, special or consequential damages (including - without limitation - lost profits, lost savings, business interruption, costs related to the removal or replacement of any products or rework charges) whether or not such damages are based on tort (including negligence), warranty, breach of contract or any other legal theory.

Notwithstanding any damages that customer might incur for any reason whatsoever, NXP Semiconductors' aggregate and cumulative liability towards customer for the products described herein shall be limited in accordance with the *Terms and conditions of commercial sale* of NXP Semiconductors.

**Right to make changes** — NXP Semiconductors reserves the right to make changes to information published in this document, including without limitation specifications and product descriptions, at any time and without notice. This document supersedes and replaces all information supplied prior to the publication hereof.

**Suitability for use** — NXP Semiconductors products are not designed, authorized or warranted to be suitable for use in life support, life-critical or safety-critical systems or equipment, nor in applications where failure or malfunction of an NXP Semiconductors product can reasonably be expected to result in personal injury, death or severe property or environmental damage. NXP Semiconductors and its suppliers accept no liability for inclusion and/or use of NXP Semiconductors products in such equipment or applications and therefore such inclusion and/or use is at the customer's own risk.

**Applications** — Applications that are described herein for any of these products are for illustrative purposes only. NXP Semiconductors makes no representation or warranty that such applications will be suitable for the specified use without further testing or modification.

Customers are responsible for the design and operation of their applications and products using NXP Semiconductors products, and NXP Semiconductors accepts no liability for any assistance with applications or customer product design. It is customer's sole responsibility to determine whether the NXP Semiconductors product is suitable and fit for the customer's applications and products planned, as well as for the planned application and use of customer's third party customer(s). Customers should provide appropriate design and operating safeguards to minimize the risks associated with their applications and products.

NXP Semiconductors does not accept any liability related to any default, damage, costs or problem which is based on any weakness or default in the customer's applications or products, or the application or use by customer's third party customer(s). Customer is responsible for doing all necessary testing for the customer's applications and products using NXP Semiconductors products in order to avoid a default of the applications and the products or of the application or use by customer's third party customer(s). NXP does not accept any liability in this respect.

**Limiting values** — Stress above one or more limiting values (as defined in the Absolute Maximum Ratings System of IEC 60134) will cause permanent damage to the device. Limiting values are stress ratings only and (proper) operation of the device at these or any other conditions above those given in the Recommended operating conditions section (if present) or the Characteristics sections of this document is not warranted. Constant or repeated exposure to limiting values will permanently and irreversibly affect the quality and reliability of the device.

**Terms and conditions of commercial sale** — NXP Semiconductors products are sold subject to the general terms and conditions of commercial sale, as published at <http://www.nxp.com/profile/terms>, unless otherwise agreed in a valid written individual agreement. In case an individual agreement is concluded only the terms and conditions of the respective agreement shall apply. NXP Semiconductors hereby expressly objects to applying the customer's general terms and conditions with regard to the purchase of NXP Semiconductors products by customer.

**No offer to sell or license** — Nothing in this document may be interpreted or construed as an offer to sell products that is open for acceptance or the grant, conveyance or implication of any license under any copyrights, patents or other industrial or intellectual property rights.

**Export control** — This document as well as the item(s) described herein may be subject to export control regulations. Export might require a prior authorization from competent authorities.

**Quick reference data** — The Quick reference data is an extract of the product data given in the Limiting values and Characteristics sections of this document, and as such is not complete, exhaustive or legally binding.

**Non-automotive qualified products** — Unless this data sheet expressly states that this specific NXP Semiconductors product is automotive qualified, the product is not suitable for automotive use. It is neither qualified nor tested in accordance with automotive testing or application requirements. NXP Semiconductors accepts no liability for inclusion and/or use of non-automotive qualified products in automotive equipment or applications.

In the event that customer uses the product for design-in and use in automotive applications to automotive specifications and standards, customer (a) shall use the product without NXP Semiconductors' warranty of the product for such automotive applications, use and specifications, and (b) whenever customer uses the product for automotive applications beyond NXP Semiconductors' specifications such use shall be solely at customer's own risk, and (c) customer fully indemnifies NXP Semiconductors for any liability, damages or failed product claims resulting from customer design and use of the product for automotive applications beyond NXP Semiconductors' standard warranty and NXP Semiconductors' product specifications.

**Translations** — A non-English (translated) version of a document is for reference only. The English version shall prevail in case of any discrepancy between the translated and English versions.

## 12.4 Licenses

### Purchase of NXP ICs with NFC technology

Purchase of an NXP Semiconductors IC that complies with one of the Near Field Communication (NFC) standards ISO/IEC 18092 and ISO/IEC 21481 does not convey an implied license under any patent right infringed by implementation of any of those standards.

## 12.5 Trademarks

Notice: All referenced brands, product names, service names and trademarks are the property of their respective owners.

**MIFARE** — is a trademark of NXP B.V.

**I<sup>2</sup>C-bus** — logo is a trademark of NXP B.V.

## 13. Contact information

For more information, please visit: <http://www.nxp.com>

For sales office addresses, please send an email to: [salesaddresses@nxp.com](mailto:salesaddresses@nxp.com)

**14. Contents**

**1 General description . . . . . 1**

**2 Features and benefits . . . . . 2**

2.1 Key features . . . . . 2

2.2 RF interface . . . . . 2

2.3 Memory. . . . . 2

2.4 I<sup>2</sup>C interface . . . . . 3

2.5 Security. . . . . 3

2.6 Key benefits . . . . . 3

**3 Applications . . . . . 3**

**4 Quick reference data . . . . . 4**

**5 Ordering information . . . . . 4**

**6 Block diagram . . . . . 5**

**7 Pinning information . . . . . 6**

7.1 Pinning . . . . . 6

7.2 Pin description . . . . . 6

**8 Limiting values. . . . . 7**

**9 Package outline . . . . . 8**

**10 References . . . . . 9**

**11 Revision history. . . . . 10**

**12 Legal information. . . . . 11**

12.1 Data sheet status . . . . . 11

12.2 Definitions . . . . . 11

12.3 Disclaimers . . . . . 11

12.4 Licenses . . . . . 12

12.5 Trademarks. . . . . 12

**13 Contact information. . . . . 12**

**14 Contents . . . . . 13**

Please be aware that important notices concerning this document and the product(s) described herein, have been included in section 'Legal information'.

© NXP B.V. 2013. **All rights reserved.**

For more information, please visit: <http://www.nxp.com>  
 For sales office addresses, please send an email to: [salesaddresses@nxp.com](mailto:salesaddresses@nxp.com)

Date of release: 19 December 2013  
 257710